

# MODEL 588TB

FOR EMPTY CONTAINER HANDLING  
WITH LIFT TRUCKS



## Standard supply includes:

- Integrated mounting to fit the truck.
- Mechanical pile slope (MPS), floating function in the end-posts.
- Two vertical ISO twistlocks.
- Hydraulic telescoping.
- Hydraulic sideshift.
- Solenoid valves for all hydraulic functions.
- Electrical and mechanical twistlock protection system.
- Electric twistlock indication.
- Electric telescoping protection system.
- Lift interrupt signal.
- LED-indication lights.
- LED-work lights.

## The ELME Spreader Model 588TB is a telescopic side lift spreader with vertical twistlocks for the handling of single empty ISO containers.

The spreader is designed to be integrated on the carriage of a forklift truck. 588TB has a low single profile main frame which enhances visibility when high stacking.

For easy and fast handling of containers the heads on the end-posts have a sideways floating function. Mechanical pile slope (MPS) in 588TB are vertical floating end-posts, including the bottom support. Floating end-posts simplifies picking up containers in a slanted angle.

### TWISTLOCK SYSTEM

The twistlock system is manufactured in a rugged design and is well-proven since many years. 588TB has hardened ISO quick exchange pendular twistlocks. Hydraulically activated and mechanical interlocking against faulty locking and unlocking.

The vertical twistlock principle offers the following features:

- Two twistlocks enter the top corner castings and lock the spreader onto the container.

- 588TB is shorter than the container it is handling which means that all containers can be fully blockstacked and still remain accessible.

- ISO containers and Binnencontainers can be picked up without any modifications to the spreader.

### CONTROL AND PROTECTION SYSTEM

Electrical systems monitor the state of the spreader at all times. Indicator lights advise the operator when the spreader is correctly seated, locked or not locked. Each signal is a precondition for the important protection functions of the spreader. Such as twistlock activation, telescoping and lift interrupt.

# MODEL 588TB

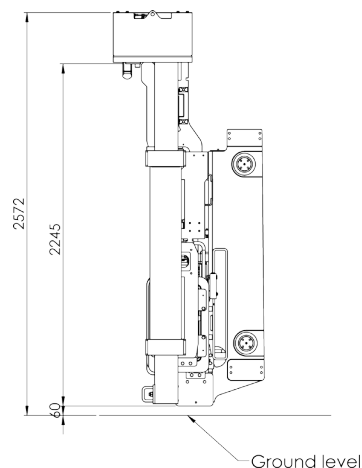
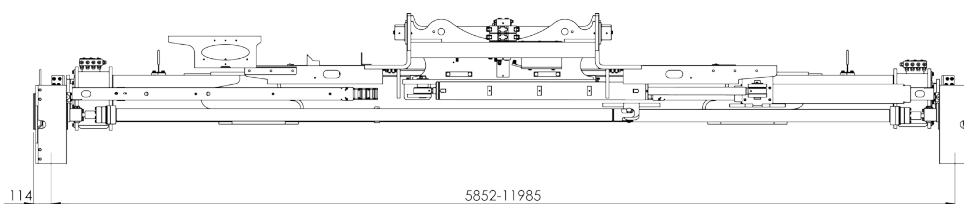
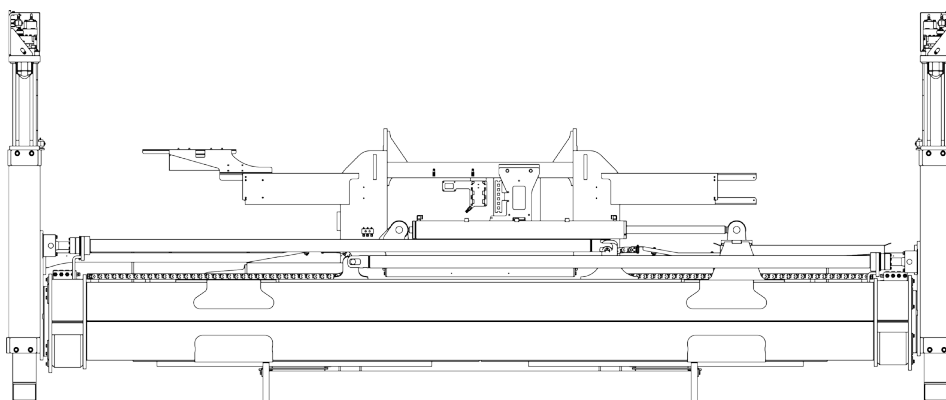

## Technical specifications

Type of lifting system	Two vertical twistlocks
Type of stacking	Normal and block stacking
Spreader weight (TW)	3 500 kgs
Carriage weight (TW)	1 110 kgs
Lifting capacity (SWL)	9 tonnes
Telescopic positions	20 and 40ft
Telescoping speed	20-40ft < 14 sec.* 40-20ft < 17 sec.*
Sideshift	± 300 optional ± 600 mm
Mechanical pile slope (MPS)	At 20ft position: 200 mm At 40ft position: 200 mm
Hydraulics	operating pressure up to 140 bar flow 40-60 L/min
Electric - control voltage	24 VDC
Colour	Black grey RAL 7021
Paint thickness	150 µ

\* Calculated speed at 20° C.

All specifications are subject to change without notice. A list of options enables you to adapt the spreader more precisely to your needs and further information is available on request.



588TB.

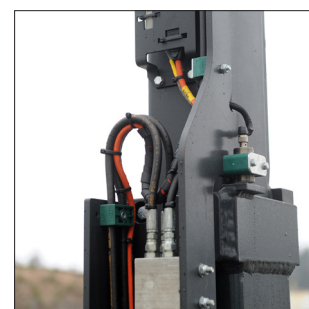

Surface-mounted hose and cable routing.



LED-work light.

### HEAD QUARTER AND PRODUCTION

#### ELME Spreader AB

Phone +46 476 558 00  
Email sales@elme.com

### SALES AND SPARE PARTS

#### ELME Spreader Trading (Shanghai) Co., Ltd

Phone +86 21 5169 8922  
Email sales.cn@elme.com

### SPARE PARTS

#### ELME Americas Inc.

Phone +1 731 588 02 20  
Email sales.us@elme.com

For details, spare parts and more products, visit [www.elme.com](http://www.elme.com).

**ELME**<sup>TM</sup>  
Swedish Spreader Systems